



XPulse and XPulse Plus Instruction Manual

Thank You!

Thank you for choosing Nautic Alert® XPulse. Proudly engineered and assembled in the USA. We are confident your new purchase will provide an outstanding experience of *precision engineered technology*. Please take a few minutes to read through the instruction manual and familiarize yourself with the installation and setup process.

In the unlikely event your XPulse encounters technical issues, please consult the warranty section of this manual.

Please register your product at <https://www.nauticalert.com/support/register-product/>

and see additional product info at www.nauticalert.com

To ensure you have the latest instruction manual, please visit <https://www.nauticalert.com/support/instruction-manuals/>

Contents

Technical Specifications	3
Product Labeling Requirements.....	3
XPulse Overview	4
XPulse Dimensions	5
XPulse Plus Dimensions	6
XPulse Wiring Diagram.....	7
Wiring Description	8
Shore Power Detection	9
DC Battery Bank Inputs	9
Security Inputs and 12V Regulator Output.....	9
Siren Output.....	9
Wireless Status and Pairing.....	9
Configuring Applications.....	9

Technical Specifications

Operating Voltage: 12V, 24V, and custom DC sources.
Absolute min/max 6V-37V for DC bank inputs
12V DC for AC Shore Power Input

Operating Current (@12V):

XPulse: 25mA nominal

XPulse 12V security/siren regulator output: 500mA max combined

XPulse Plus: 150mA nominal, 425mA max

Integrated Siren: 95dB (available Q1 2018)

Operating Temperature: -10 to 60C

Patents: US8531316 B2, USD687733 S1, US20140266793 A1

Product Labeling Requirements

Device Contains FCC ID: MCQ-S2CTH or MCQ-PS2CTH

This device complies with Part 15 of the FCC Rules. Operation is subject to the following two conditions:

(1) This device may not cause harmful interferences, and (2) this device must accept any interference received, including interference that may cause undesired operation.

XPulse Overview



XPulse and XPulse Plus add additional applications to Insight, which includes 4 battery banks, AC Shore power monitoring, and a 4-zone security interface with supervision support.

XPulse is designed to operate with existing or Nautic Alert pre-certified hardwired 12V tolerant N.O or N.C. standard security sensors. N.O. sensors can be wired together in a single zone.

XPulse Plus is designed to add wireless security and safety sensors. With XPulse Plus, installation is a breeze. Nautic Alert pre-programs sensors and zones, so when you receive your system, everything is ready to go once you mount your security and safety sensors. Each XPulse Plus can support up to 32 wireless sensors, which then are mapped to one of four alarm zones. Wireless sensors are supervised, meaning low-voltage, inactivity, and tamper detection events send notifications.

Security and safety sensors include outdoor and indoor motion, smoke, door/hatch contacts, and one or more man-overboard (MOB) sensor, and others. See www.nauticalert.com for details.

Insight can support up to two XPulse units, in any combination (XPulse/XPulse Plus), giving a total of 8 security zones, 8 battery banks, and 2 shore powers.

XPulse models available Q1 2018 will be able to power Insight for power fault redundancy, and also contain an integrated siren which can sync to Insight's critical events, and provide both an electrical interconnect and optional integrated siren to be able to give audible and visual siren events throughout the boat.

XPulse Dimensions

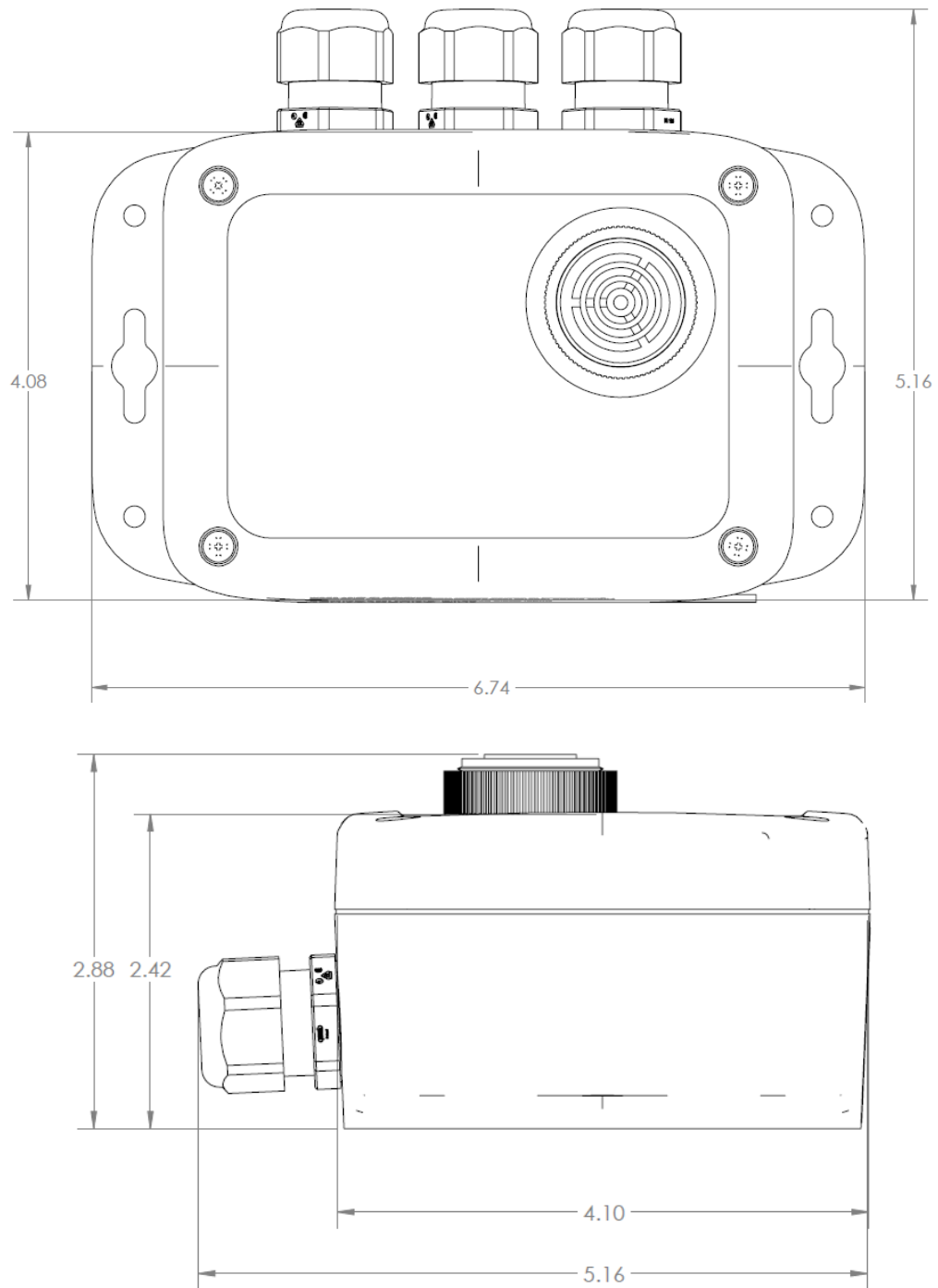

* Siren feature available Q1 2018

XPulse Plus Dimensions

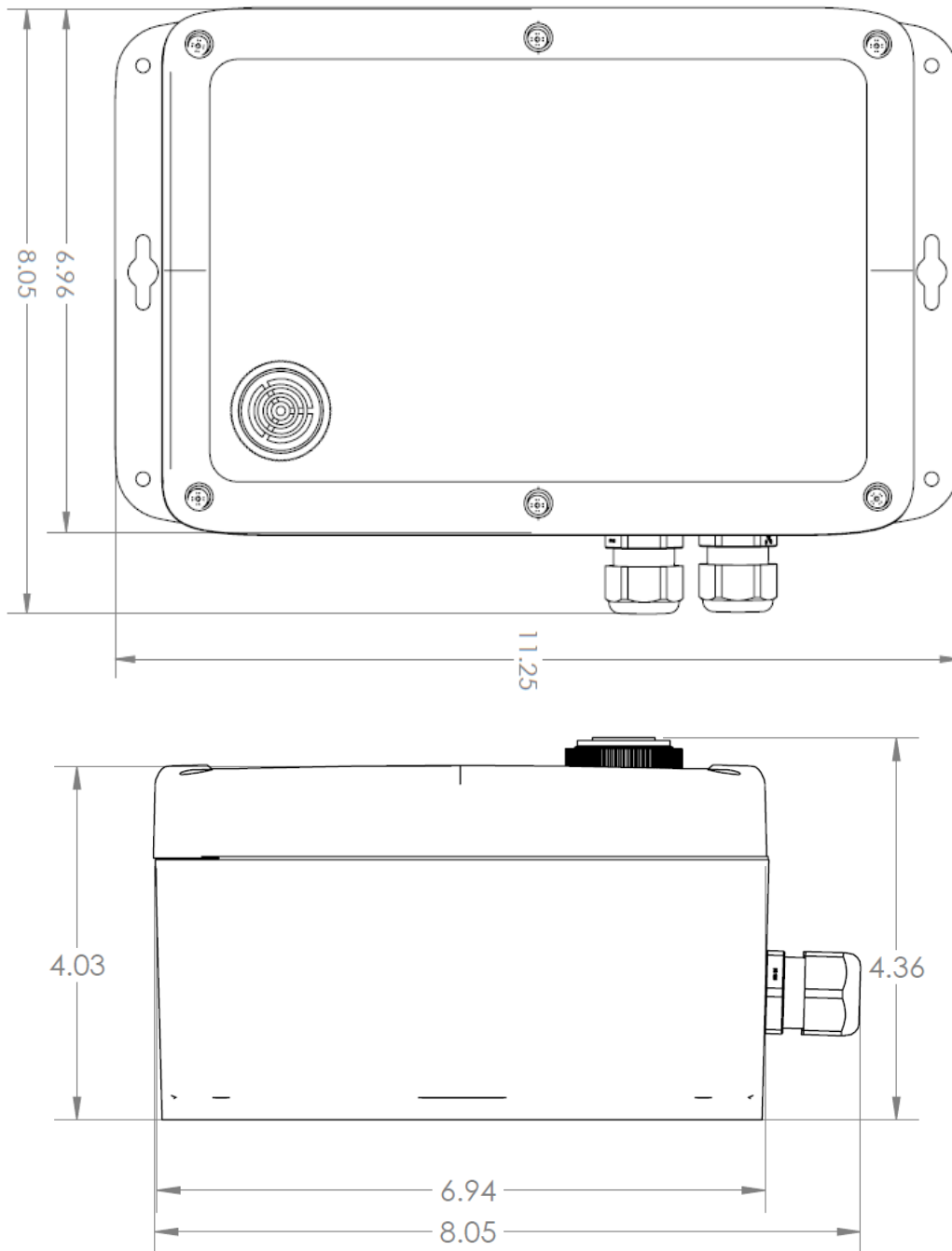

* Siren feature available Q1 2018

XPulse Wiring Diagram

The following wiring diagram is from the perspective of looking down at the circuit board once the top cover is removed.

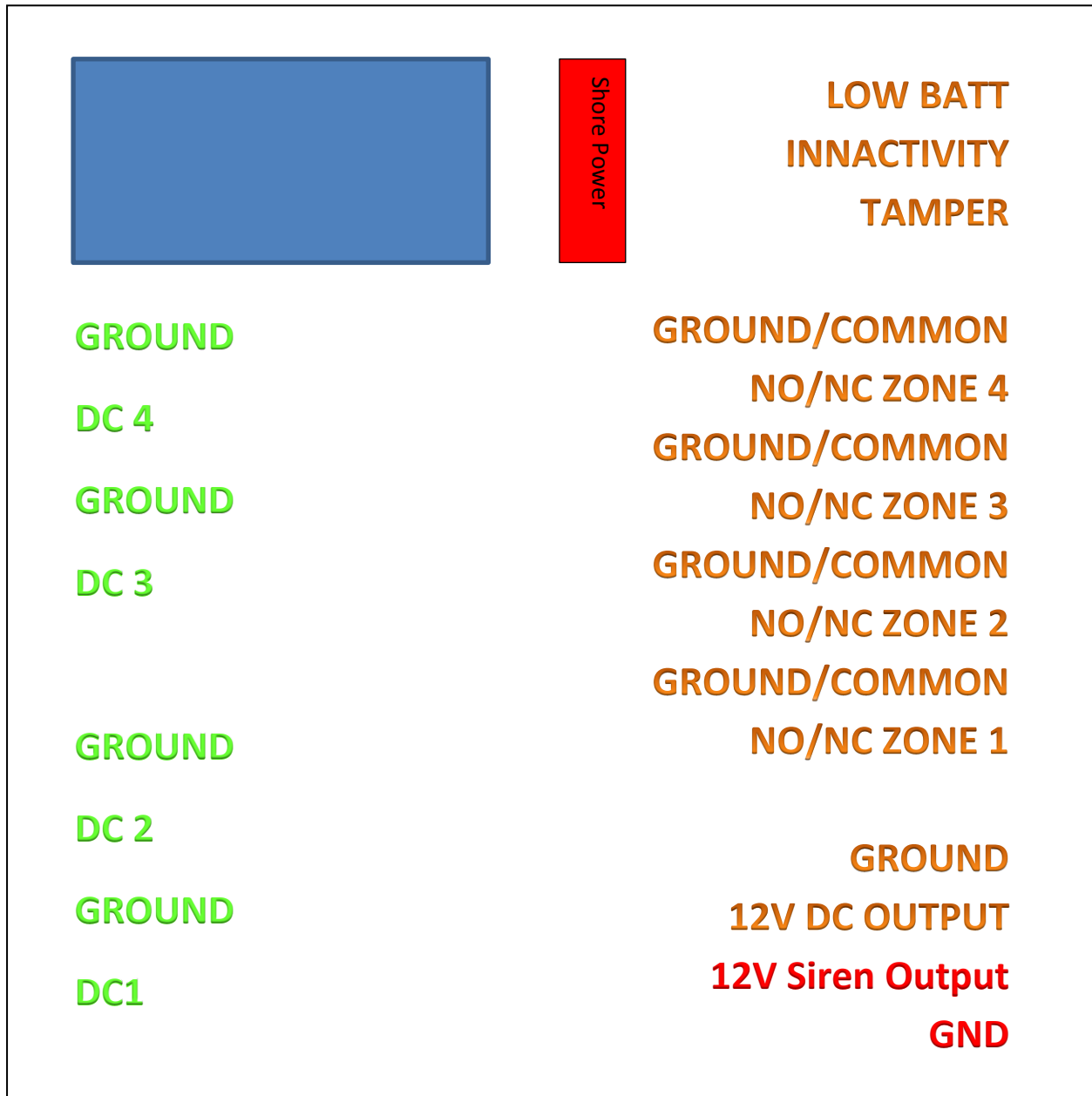

On XPulse Plus, the DC battery bank, shore power inputs, and 12V Siren Output can be used, but all security inputs are reserved, ie: Low batt, inactivity, tamper, ground/common, no/nc zones 1-4, 12V DC output/ground.

Wiring Description

All wiring should follow ABYC standards, inline fuses are recommended.

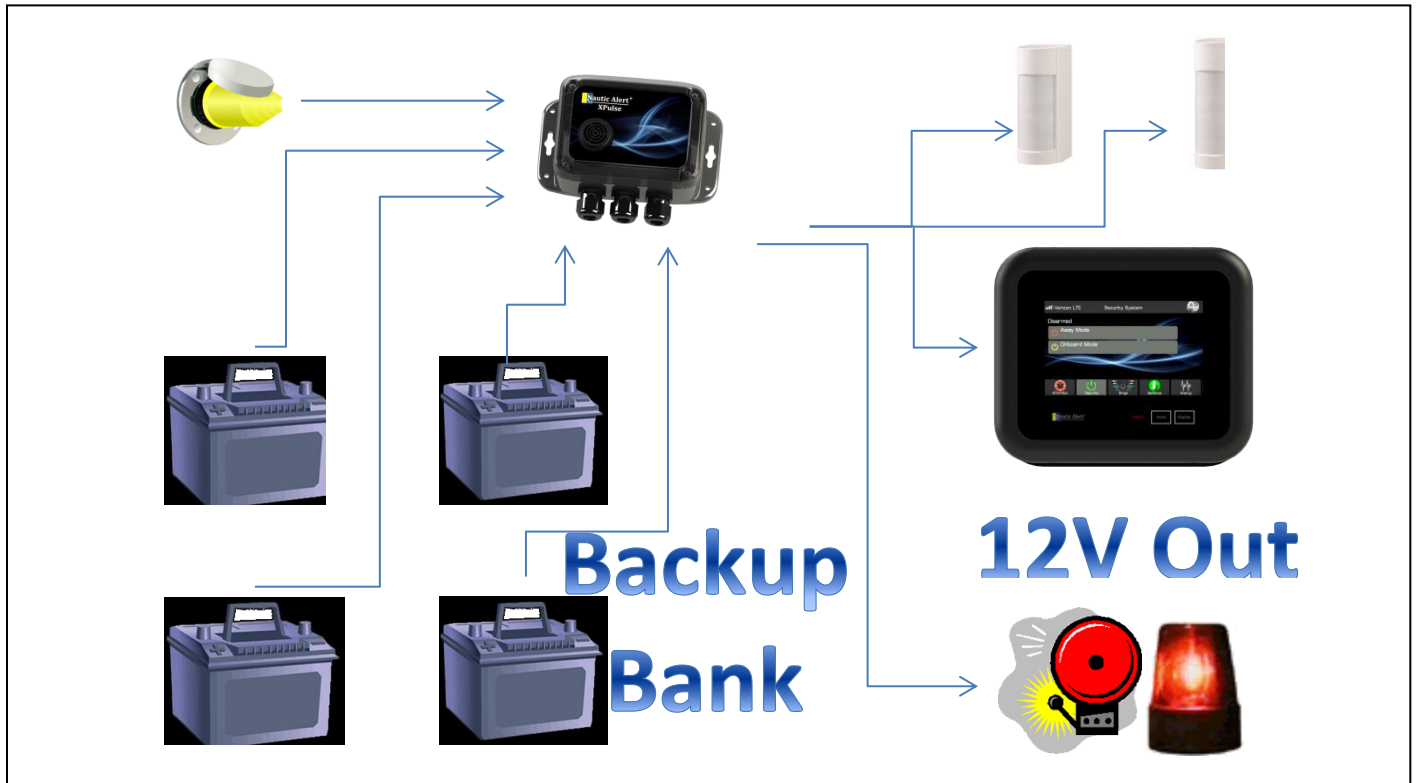

XPulse will use incoming power from AC and DC banks to regulate 12V DC output to attached alarm sensors, optionally for *powering Insight with battery backup, and for powering the *integrated siren or an externally attached siren/alarm. In this way, it's possible to add one or more backup batteries dedicated to powering alarm sensors and XPulse for full power fault redundancy and backup, as well as audible and visual alarms throughout the boat.

Prior to tightening cable glands, adding silicon adhesive to the inner gasket of the cable glands is recommended to create and maintain a water-tight interconnect.

Always disconnect incoming AC and DC battery bank power before wiring security sensors.

*** New features available Q1 2018**

Shore Power Detection

AC Shore Power detection uses an AC/DC converter to 12V barrel jack source. The presence of the barrel jack is automatically detected and used to enable/disable shore power monitoring on Insight.

DC Battery Bank Inputs

DC inputs should be wired to 6-37V DC sources.

Security Inputs and 12V Regulator Output

Hardwired security sensors must be 12V tolerant, and can derive their power from XPulse's 12V regulated output. Tamper, Inactivity, and Low Battery signals are also 12V. DC battery sources and shore power input are used to feed power to this regulator for fault redundancy and high-availability.

The total current used by all attached devices must not exceed 500mA nominal on 12V.

Multiple N.O. sensors can be wired together into a single zone. In this configuration, if one sensor closes, the other sensors are masked, thus, only one sensor's output can be detected at a time. For example, all deck sensors could be wired together to detect the presence of an intruder on the deck. On Insight, this zone could be configured with the description of "deck". Any sensor that detects motion will trigger an alert for that zone.

When selecting wireless sensors to use with XPulse Plus, please notify your dealer about how you would like your sensors mapped to the 4-zones available. XPulse Plus is pre-programmed with all wireless sensors at the time of order, so everything is setup and ready to work out-of-the box.

Siren Output

The integrated siren can sync with Insight's critical alarms, which include high/critical water level, critical DC voltage, anchor drift, security zone alarms, and more. The integrated siren can easily be disconnected and siren block terminals used to power a 12V audible/visual device. The total current draw, in addition to the 12V regulator output block, must not exceed 500mA.

Wireless Status and Pairing

The wireless status LED indicates the communication status of XPulse in the following manner:

- Fast blink- Not paired and searching for an Insight with pairing enabled
- Slow blink- Paired and searching for its paired Insight
- Solid- Paired and communicating with Insight

To re-enable pairing, simply push the "Re-Pair" button located on Insight's circuit board.

Configuring Applications

For configuring and monitoring XPulse's sensor data, see Insight's user manual.